

HOT DOG WARMER
REF : SH3



USE AND CARE MANUAL

HOT DOG WARMER REF : SH3



Before operating this product, please read these instructions completely

L2G SAS 17, AVENUE DU 24 AOÛT 1944
BP90690-69969 CORBAS CEDEX
TÉL. : +33(0)4 72 23 23 98 FAX : +33(0)4 72 23 23 99



CONTENTS

Instructions	3
Applicability	3
Parameter	3
Electrical Diagram	3
After-sales service	3

Welcome your selecting of our product. Please read the manual carefully before you install and use the product and feel free to contact us if you have any suggestion with it.

INSTRUCTIONS

1. Remove the package and wipe the product with wet cloth.
2. It is normal that it may appear a little smog at the first time used.
3. Never switch on the appliance without water in the appropriate filling tray, as this could damage the appliance.
4. The three heating tube is control by the left switch ,and it is heating through PTC,with auto-thermostat function.
5. The temperature of the water dish is controlled by the thermostat fixed in the middle.
6. The master switch of the water dish is on the right.

APPLICABILITY

It is suitable for the snack store,hotel,restaurant,bus station,airport ETC

PARAMETER

VOLT	POWER	SIZE
AC 220~240 V	600 W	48X30X38 cm

ELECTRICAL DIAGRAM

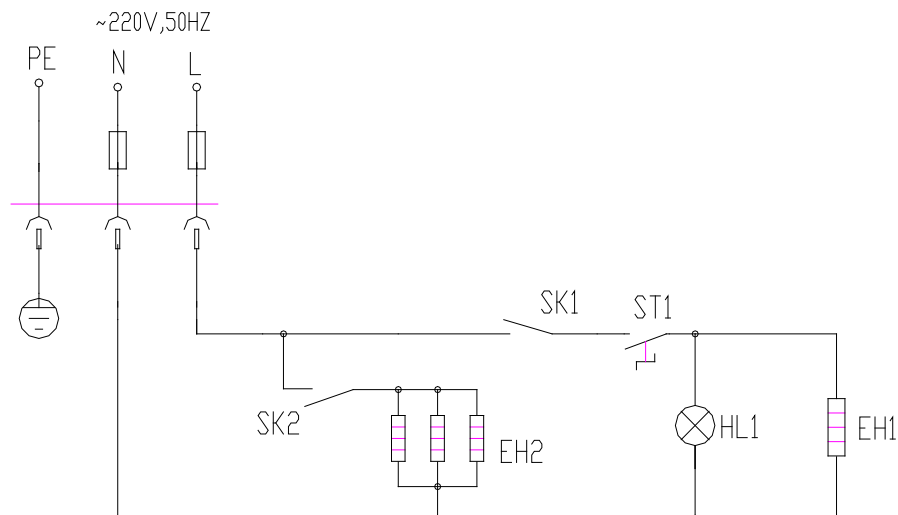

MAINTENANCE

1. Cut off the power supply before cleaning to avoid of the accident.
2. To wipe the product and the power line with un-corrosion cleanser after used,water flush is forbidden and this would destroy the function of the product.
3. Keep the machine clean and put it in the well- ventilated ,un-corrosion place when you don't use at a short time.